



P R O F E S S I O N A L



WAHL (UK) LTD

Sterling House
Clipper Close
Ramsgate
Kent
CT12 5GG

Customer Services

T: 01227 740066

W: www.wahl.co.uk

E: customer.services@wahl.co.uk

**CORDED 2-SPEED CLIPPERS
OPERATING MANUAL**

For Model Number:
8250L

IMPORTANT SAFEGUARDS

When using your electrical appliance, basic precautions should always be followed, including the following:

READ ALL INSTRUCTIONS AND SAFEGUARDS BEFORE USING THIS APPLIANCE.

DANGER

To reduce the risk of death or injury by electric shock:

1. Do not reach for an appliance that has fallen into water. Unplug immediately from the outlet. Note: Some electrical parts inside the appliance are electrically live, even with the switch “OFF - (0).”
2. Do not use while bathing or in a shower.
3. Do not place or store appliance where it can fall or be pulled into a tub or sink. Do not place in or drop into water or other liquid.
4. Always unplug this appliance before cleaning.
5. Always unplug this appliance from the electrical outlet immediately after using.

WARNING

To reduce the risk of burns, electrical shock or injury to persons:

1. This appliance can be used by children aged from 14 years and above and persons with reduced physical, sensory or mental capabilities or lack of experience and knowledge if they have been given supervision or instruction, by a person responsible for their safety, concerning the use of the appliance in a safe way and understand the hazards involved. Children should be supervised to ensure that they do not play with the appliance. Cleaning and user maintenance shall not be made by children without supervision.
2. Use this appliance only for its intended use as described in this manual. Do not use
3. attachments not recommended by the manufacturer.
4. Never operate this appliance if it has a damaged cord or plug, if it is not working properly, if it has been dropped or damaged, or if it has been dropped into water. Keep the cord away from heated surfaces.
5. Never operate the appliance with the air openings blocked or while on a soft combustible surface, such as a bed or couch, where air openings may be blocked. Keep the air openings (if any) free from lint, hair or the like.
6. Do not use outdoors or operate where aerosol (spray) products are being used or where oxygen is being administered.
7. Never drop or insert any object into any opening.
8. Do not use this appliance with a damaged or broken comb nor with teeth missing from the blades, as injury may occur.
9. During use, do not place or leave the appliance where it is expected to be subject to damage by an animal or exposed to weather.
10. To disconnect, turn all controls to “OFF - (0),” then remove plug from outlet.
11. Turn all controls to “OFF - (0)” before placing on or removing blades or attachments.
12. An appliance with a permanently attached cord should never be left unattended when plugged in.
13. Keep this appliance dry.
14. Cutting blades may become hot after prolonged use.

SAVE THESE INSTRUCTIONS

THIS APPLIANCE IS FOR COMMERCIAL USE ONLY

Use animal clippers for trimming purposes only (animal hair and animal fur).

CLEANING AND GENERAL CARE

- Before cleaning/maintenance, switch the equipment off and remove the main plug from the socket.
- Never immerse the unit in water.
- Each time after use remove any hairs from the cutting blade using the cleaning brush.
- Clean the body of the clipper with a soft, damp cloth. Never use solvents or scouring agents.
- The cutting head should be cleaned and oiled frequently with Wahl Clipper Oil in order to maintain its good cutting performance and thus ensure a long service life.
- The cutting head should be replaced if the cutting performance is reduced after extended use despite regular cleaning and lubrication.
- During use always be sure the cord is not twisted or running over any sharp objects that might cut the cord insulation.

OPERATION:

1. Turn unit on/off

Two Speed: Push the power switch to (I) for the low speed and to the (II) for the high speed.

To turn unit off push the power switch to the center position (0).

2. Remove/replace blade: The clipper should be switched off before removing blades. Remove blade. The cutting head can be removed by pressing the button under the blade and pushing the blade away from the housing. To refit the blade set, the clipper should be turned on and running. Fit the blade into the metal guide and press it into place. There will be a definite “click” when the blade is snapped into place.

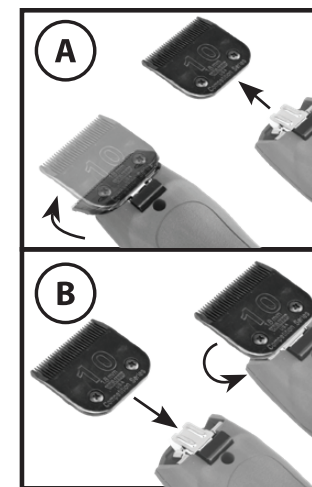

CHANGING THE CUTTING HEAD (BLADE) FIG.A

The cutting head can be removed by pressing the gray button under the blade and pushing the blade away from the housing. The clipper should be switched off before removing blades.

To refit the blade set, the clipper should be turned on and running. (FIG.B) Fit the blade into the metal guide and press it into place. There will be a definite “click” when the blade is snapped in place.

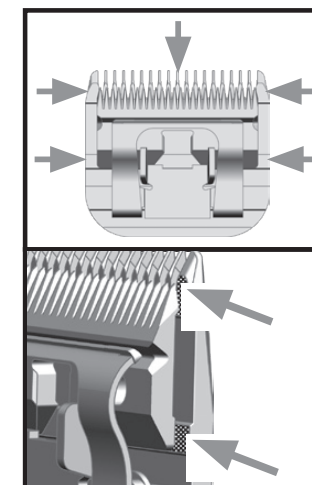

BLADE CARE AND OILING

In order to ensure that you get the most life and performance out of the clipper, we recommend oiling daily. To oil it properly, the clipper should be held so the blades are in a downward position. Place one drop of Wahl oil in the center of the movable top blade and one drop of oil on each end of the top blade. Turn clipper switch ON and run to distribute the oil. When oil is evenly distributed, turn clipper OFF and wipe off excess oil with a soft cloth. Periodically oil heel of blade (shown in image) to reduce blade friction. (USE WAHL OIL ONLY) **WIPE OFF EXCESS OIL** so it does not run into the motor compartment. Oil in the motor compartment will eventually lead to poor motor performance. Blades should be oiled after using disinfectant or sanitizing solution.